



Instructional Manual HD-SERIES UNDERCOUNTERS



Undercounters

UR27, UR48, UR60, UR72, UF27, UF48

This manual contains important information regarding your Culitek unit. Read this manual thoroughly prior to equipment setup, operation, and maintenance. Failure to comply with regular maintenance guidelines outlined in this manual may void the warranty.

TABLE OF CONTENTS

- 1. Terms & Conditions2
- 2. Introduction4
- 3. Manufacturer Retained Rights & Responsibilities4
- 4. Transportation & Storage4
- 5. Commissioning4
 - Positioning4
 - Initial Cleaning5
 - Connection to Electrical Supply5
 - Connection to Drains5
- 6. Technical Characteristics5
 - Noise & Vibration5
 - Use of Equipment5
- 7. Usage6
 - Activation6
 - Storage of Food6
 - Defrosting6
- 8. Maintenance Instructions6
 - Period of Inactivity of Cabinet.....6
- 9. Troubleshooting7
- 10. Technical Service7
- 11. Improbable Risks7
- 12. Replacement of Parts7
- 13. Dismantling of Unit.....8
- 14. Electrical Control Circuit Diagrams8
- 15. Technical Parameters9
- 16. Official Approval & Rules10

1. TERMS AND CONDITIONS

Two Year Warranty

All claims for parts or labor must be made directly through Culitek, and must include the model, the serial number, proof of purchase, date of installation, and all pertinent information supporting the alleged defect. In case of compressor replacement under warranty, either the compressor or compressor tag must be returned to Culitek, along with above listed information. **Failure to comply with warranty policies will result in voided claims.**

Two Year Parts & Labor Warranty

Culitek warrants all new refrigerated components, such as the cabinet and all parts, to be free from defects in materials or workmanship. Culitek's obligation under this warranty is limited to a period of two (2) years from the date of shipment from Culitek. All parts covered under this warranty that are defective within two (2) years from the date of shipment from Culitek are limited to repair or replacement (including labor charges) of defective parts or assemblies. The labor warranty shall include standard straight time labor charges only and reasonable travel time, as determined by Culitek.

Additional Three-Year Compressor Warranty

In addition to the two (2) year warranty, Culitek warrants its sealed compressor to be free from defects, in both material and workmanship, under normal and proper use and maintenance service for a period of three (3) additional years from the date of original installation, but not to exceed five (5) years. Compressors that have been determined to be defective from Culitek within this extended period will be either repaired or replaced with a compressor or compressor parts of similar design and capacity, according to Culitek's discretion. The three (3) year extended compressor warranty applies only to sealed parts of the compressor and does not apply to any other parts or components. This includes the cabinet, paint finish, temperature control, refrigerant, metering device, motor starting equipment, fan assembly, and other electrical components, etc.

Compressor Warranty

The (5) five-year compressor warranty will be void if the following procedure is not carefully adhered to:

1. System contains R290 refrigerant and lubricant. The lubricant has rapid moisture absorbing qualities.
2. Drier replacement is very important and must be changed when a system is opened for servicing.
3. Micron level vacuums must be achieved to insure low moisture levels in the system.
4. Compressor must be obtained through Culitek, unless otherwise specified in writing, through Culitek's warranty department.

What is NOT Covered by the Warranty

Culitek's sole obligation under this warranty is limited to either repair or replacement of parts, subject to the additional limitations below. This warranty neither assumes nor authorizes any person to assume obligations other than those expressly covered by this warranty.

ROUTINE MAINTENANCE REQUIREMENTS MUST BE FOLLOWED, OR WARRANTY IS VOID.**No Consequential Damages**

In no event will Culitek be responsible for economic loss, profit loss, or special, exemplary, punitive indirect, or consequential damages, including without limitation losses or damages arising from food or product spoilage, regardless of whether or not they result from equipment failure.

Warranty is Not Transferable

This warranty is not assignable and applies only to the original purchaser/user to whom delivered. ANY SUCH ASSIGNMENT OR TRANSFER SHALL VOID THE WARRANTIES HEREIN AND SHALL VOID ALL WARRANTIES, EXPRESSED OR IMPLIED, INCLUDING ANY WARRANTY OF MERCHANTABILITY OR LABOR COVERAGE FOR COMPONENT FAILURE OR OTHER THE WARRANTY PACKET PROVIDED WITH THE UNIT.

Alteration, Neglect, Abuse, Misuse, Accident, Damage During Transit or Installation, Fire, Food, or Acts of GOD

Culitek is not responsible for the repair or replacement of any parts that are determined to have been subjected after the date of manufacture to alteration, neglect, abuse, misuse, accident, damage during transit or installation, fire, flood, or act of God.

Improper Electrical Connections

Culitek is not responsible for repair or replacement of failed or damaged components, resulting from electrical power failure, the use of extension cords, low voltage, or voltage drops to the unit.

The two (2) year parts & labor warranty and the additional three (3) year compressor warranty are as described above. These warranties are exclusive and are in lieu of all other warranties and seller disclaims any implied warranty of merchantability or that the goods will be fit for a particular purpose. Seller also disclaims any implied warranties of non-infringement. There are no warranties which extend beyond the description on the face hereof.

Stocking Period

Equipment distributed by stocking dealers are permitted a period of up to six (6) months for time equipment is in-stock before sale to purchaser/user before warranty starts. For this extended warranty stocking period to be honored, customer must provide model number of the unit, the serial number, and dated proof of purchase.

Outside U.S.A. and Canada

This warranty does not apply to areas outside the continental USA. Culitek is not responsible for any warranty claims made on products sold or used in such areas.

Residential

Culitek assumes no liability for parts or labor coverage for component failure, factory defect or any other damages for units installed in non-commercial foodservice or residential applications.

** In some cases, a 25% restocking fee may be charged for returned items.*

** Culitek may at any time modify equipment in order to provide and insure a superior product. Change is sometimes necessary to keep up with today's high standards in our industry. Culitek reserves the final interpretation of all public materials.*

2. Introduction

This equipment has been produced to be internally or externally in its aesthetics and componability. In response to the specific needs of customers, it has been mechanically and aesthetically checked in every aspect before dispatch. For the correct utilization of the equipment, carefully read the instructions, observe all the recommendations contained therein, and consign this manual of which constitutes an integral part of the essence of the equipment, to the enduser who is requested to retain it for future consultation. By observing these recommendations, you will guarantee the extended trouble-free operation of the equipment.

3. Manufacturer Retained Rights & Responsibilities

It is forbidden to reproduce, partially or totally, these instructions without the express authorization of the manufacturer. The manufacturers deny all responsibility to third parties in consequence of:

- ▲ Non-observance of the warnings and instruction contained in the test
- ▲ Non-observance of the parameters of utilization of the equipment
- ▲ Unreasonable or wrongful utilization by untrained personnel
- ▲ Use non-conforming to local statutes
- ▲ Unauthorized modifications and/or repairs undertaken by untrained or unauthorized personnel
- ▲ Utilization of non-original spare parts or accessories
- ▲ Exceptional occurrences
- ▲ Imprecise instructions contained for whatever reason in the current manual

The manufacturer reserves the right to introduce any modification deemed necessary without warning.

4. Transportation & Storage

The equipment is wrapped in absorbent material and contained and fixed within a wooden platform and paper box. Units should be stored within a protected and covered environment at a temperature between $-25^{\circ}\text{C}/-13^{\circ}\text{F}$ and $55^{\circ}\text{C}/131^{\circ}\text{F}$, with an ambient humidity between 30% and 95%. Do not stack more than four items.

5. Commissioning

Carefully read the label on the equipment. Do not cover for any reason whatsoever and replace them immediately if damaged. Do not remove protection or paneling that require the usage of tools.

Positioning:

In respect to the dimensions, ensure the space reserved for the equipment permits its correct utilization and ease of maintenance. After carefully unpacking the display case, remove the white PVC protective film and all of the manufacturer's material which safeguards the item in transit. Place the cabinet on a flat surface and level it by screwing and adjusting the leveling legs to ensure its efficient operation. The cabinet must be lifted only from the exterior of the base to avoid the possibility of damage. Do not move the cabinet by application of pressure to the surface.

If the device has been positioned horizontally (integral condensing unit), wait two hours before activating it. Packing and protective film should be disposed of as indicated by the local authorities. The equipment must not be installed within explosive ambience, in the open air, or exposed to rain. The correct setting is distant from direct sources (radiators, direct lighting, etc.) and protected from direct sunlight and draughts. Air circulation must be freely maintained around the condensing unit, be it integral or remote. Non-observance of these specific conditions will detrimentally affect the cabinet.

Initial Cleaning:

Before use, all parts of the cabinet should be cleaned. For the walls and all the internal parts, use an antibacterial detergent. For the plastic parts, use a moistened cloth. Dry with a soft clean cloth. Use little or no water. Do not use harsh or abrasive solvents or detergents. During cleaning, do not approach bare-handed parts which could cut (evaporator, condenser, etc.). Always use protective gloves.

Connection to Electrical Supply:

Check that the electrical supply conforms to the requirements listed on the factory label and that it is provided with a fall-safe protection or automatic circuit breaker with an efficient connection. Should there be no electrical safety feature, have an omnipolar switch installed by a qualified technician, as indicated in the safety regulations, with a minimum clearance of the contacts of 3MM, where the cabinet has to be installed at some distance from the electrical source, conforming to local regulations. Cabinets supplied with integral condensing units are provided with an appropriate plug fitted with a neutral and earth. The supply cable must be well stretched, to avoid coiling and superimposition. It must not be exposed to the possibility of damage by third parties. It should not be in contact with liquids, water, or heat sources. In the event of damage, it must be replaced by a qualified technician. Always avoid the use of reducers or adapters.

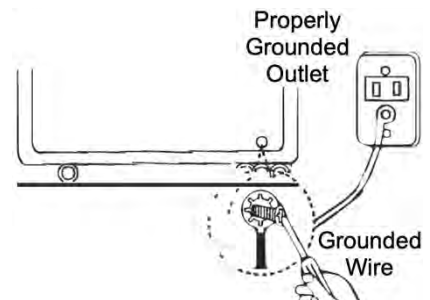
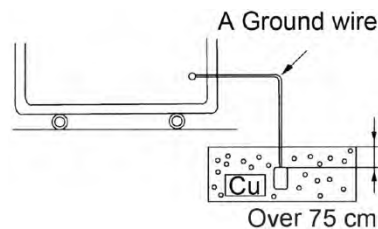
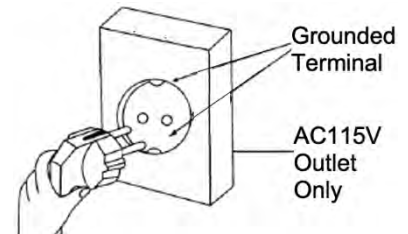

Connection to Drains:

The dispersal of defrost water is automatic in models with an integral condensing unit.

6. Technical Characteristics

Noise & Vibration:

It is not necessary to provide sound insulation, as the sound level of the equipment fitted with integral hermetic condensing unit does not exceed 70 dB. Under normal conditions, the equipment does not generate vibrations, which affect surroundings.

Use of Equipment:

Do not utilize the equipment to store medical supplies. The optimum operational temperatures are between 33°F to 40°F in refrigerated units and -8°F to 0°F in freezer units with relative humidity within 55%.

Possible applications include refrigeration, preparation and sale of salads, fruits, vegetables, and cold dishes.

7. Usage

Activation:

Power connection and adjust the thermostat.

Storage of Food:

In order to obtain the best functioning of the case it is necessary to observe the following instruction:

- ▲ Place the merchandise into the unit, only after it has reached the desired operating temperature given on the digital display.
- ▲ To eliminate the risk of over-balancing, only open and fill one drawer at a time.
- ▲ Do not place uncovered hot foods or liquids inside the unit.
- ▲ Package or protect foods when possible.
- ▲ Do not limit the circulation of air inside the call with superfluous obstacles.
- ▲ Avoid frequent or prolonged openings of the door/drawers.
- ▲ Wait a few moments before reopening the door/drawer just after it has been closed.

Defrosting:

The auto defrost cycle repeats 4 times in 24 hours; its timer will reset to the time of the initial first start-up.

8. Maintenance Instructions

The smooth operation and life of the equipment are mainly determined by correct and regular maintenance. Regular cleaning is strongly recommended each month. Please follow the instructions below.

! Disconnect the unit power supply cable from the main power source prior to carrying out any type of cleaning operation.

▲ Cleaning the Exterior

Clean with mild detergent and then dry it with a soft cloth. Do not use abrasive detergents!

▲ Cleaning the Interior

Clean a minimum of once each month with a detergent suitable for use with foodstuff.

▲ Cleaning the Condenser

For efficient operation, it is advisable to clean the condenser regularly, a minimum of once every 4 months with a dry brush or vacuum cleaner.

Period of Inactivity of Cabinet:

During periods of inactivity, remove the products from the cabinet and follow instructions below.

- ▲ Remove the plug from the outlet and carefully clean the unit, as per maintenance instructions.
- ▲ Cover the cabinet with a cloth that allows air circulation in the interior.

9. Troubleshooting

▲ Cabinet does not operate

Remedies:

- Check that the plug is inserted properly in the socket
- Check that the supply plug is not damaged
- Check the on/off switch
- Check that the main voltage powers the plug

▲ Cabinet temperature is not achieved

Remedies:

- Check the on/off switch
- Check that the thermostat range is correctly regulated
- Check that the unit is not too close to a heat source
- Check that the condensing unit has uninterrupted air flow
- Check that the condenser is not dirty or closed
- Check that the unit is not in the auto defrost cycle or in the post-defrost cycle
- Check that the evaporator is not covered with frost
- Check that the stored foods, or other objects, do not inhibit proper closing of unit
- Check that the unit is not working in anomalous conditions— *overloaded with hot food or loaded in a way that prevents proper air circulation*

▲ Cabinet leaks water

Remedies:

- Check that the collecting container, or the device for the condensing water elimination, are not damaged
- Check that the discharge outlets are not blocked or obstructed
- Check that the cabinet is properly leveled

▲ Cabinet is unacceptably noisy

Remedies:

- Check that the frame does not have loose screws or bolts
- Check that the cabinet is placed in a stable position and correctly leveled

10. Technical Service

For technical service, please contact the dealer technical support department and provide them with the model number, serial number and the purchase date.

11. Improbable Risks

In case of fire, unplug unit, if possible, and use a powder fire extinguisher

12. Replacement of Parts

Before commencing any service or maintenance work, isolate the cabinet from the electrical supply. Always replace worn parts with original factory parts, which may be obtained from an authorized supplier.

13. Dismantling of Unit

The scrapping of the cabinet requires to be undertaken by specialized company, licensed by the local authorities, and observing local statutes. When dealing with polyurethane foaming material, not fire-resistant, local law and statutes must be followed. The cabinet consists of the following materials.

- ▲ Structure in steel plate
- ▲ Electrical components and cables
- ▲ Electrical compressor
- ▲ Plastic materials
- ▲ Refrigerant fluid, which must not be discharged into the atmosphere

FAILURE TO RESPECT THE EXISTING LOCAL STATUTES ARE THE RESPONSIBILITY OF THE OWNER

- ▲ Do not dispose of electrical appliances as unsorted municipal waste; use separate collection facilities.
- ▲ Contact your local government for information regarding the collection systems available.
- ▲ If electrical appliances are disposed of in landfills or dumps, hazardous substances can leak into the groundwater and get into the food chain, damaging your health and well-being.
- ▲ When replacing old appliances with new appliances, the retailer is legally obligated to take back your old appliance for disposal free of charge.

ELECTRICAL CONTROL CIRCUIT DIAGRAMS

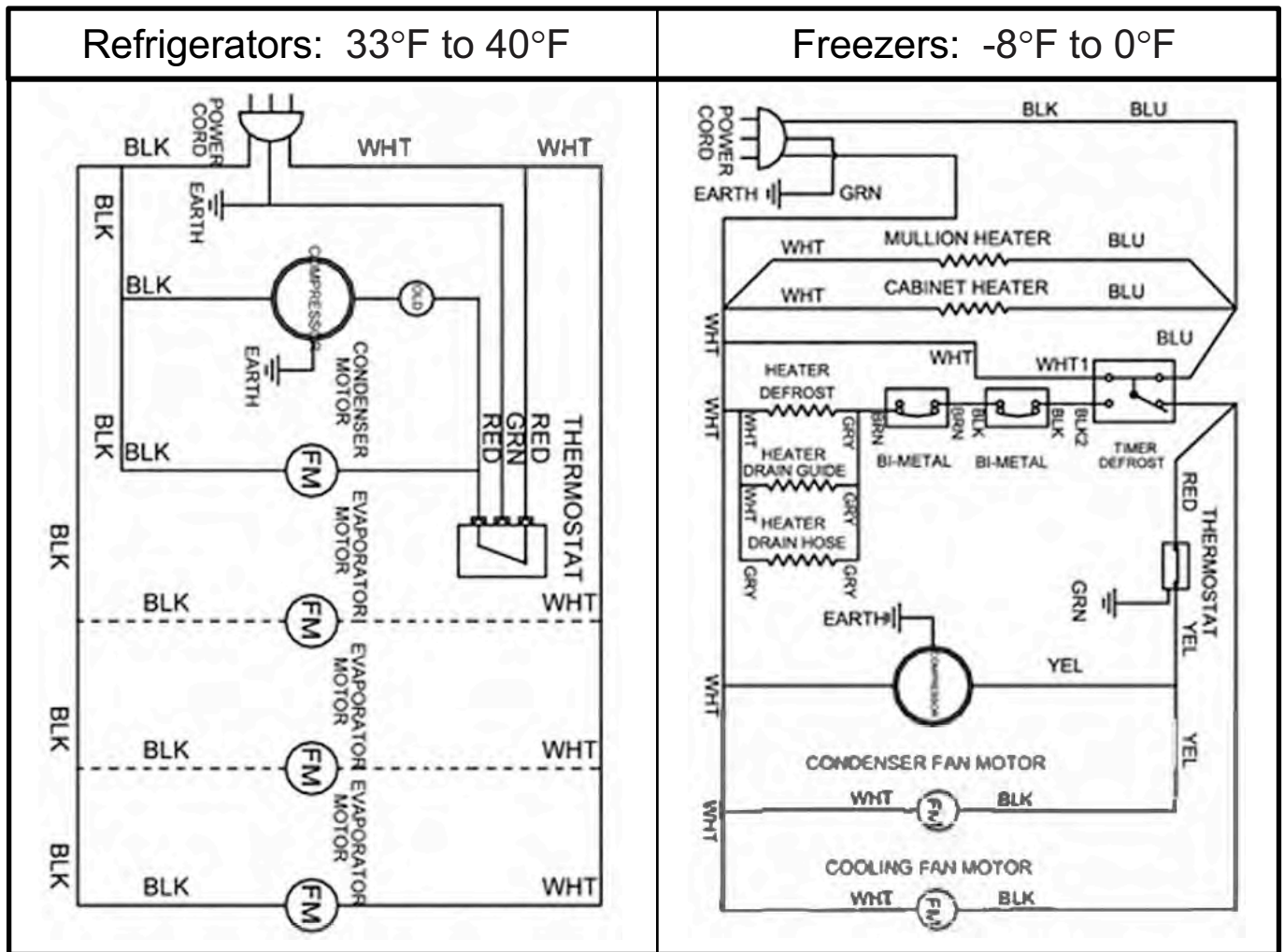

TECHNICAL PARAMETERS

Product Name	Model Number	Power Source (V)	Rating Frequency (Hz)	Input Power (W)	Rated Current (A)	Volume (Cu. Ft.)	Temperature Range (°F)	Refrigerant	Capacity (L)	Dimensions (in)
SANDWICH PREP TABLES										
27"	SP27	115V	60	270	2.3	7.2	33°F to 40°F	R290	184	27 ¹ / ₂ "W × 30"D × 44 ³ / ₁₀ "W
48"	SP48	115V	60	370	2.3	13.4	33°F to 40°F	R290	340	48 ¹ / ₅ "W × 30"D × 44 ³ / ₁₀ "W
60"	SP60	115V	60	370	2.8	17.2	33°F to 40°F	R290	516	60 ¹ / ₅ "W × 30"D × 44 ³ / ₁₀ "W
72"	SP72	115V	60	430	2.8	21.1	33°F to 40°F	R290	538	72 ⁷ / ₁₀ "W × 30"D × 44 ³ / ₁₀ "W
MEGA TOP - SANDWICH PREP TABLES										
27"	SPM27	115V	60	270	2.3	7.2	33°F to 40°F	R290	184	27 ¹ / ₂ "W × 34"D × 46 ³ / ₅ "W
48"	SPM48	115V	60	370	2.3	13.4	33°F to 40°F	R290	340	48 ¹ / ₅ "W × 34"D × 46 ³ / ₅ "W
60"	SPM60	115V	60	370	2.8	17.2	33°F to 40°F	R290	516	60 ¹ / ₅ "W × 34"D × 46 ³ / ₅ "W
72"	SPM72	115V	60	430	2.8	21.1	33°F to 40°F	R290	538	72 ⁷ / ₁₀ "W × 34"D × 46 ³ / ₅ "W
PIZZA PREP TABLES										
44"	PP44	115V	60	280	2.3	9.7	33°F to 40°F	R290	396	44"W × 33 ¹ / ₁₀ "D × 44"H
67"	PP67	115V	60	410	2.8	18.5	33°F to 40°F	R290	566	67"W × 33 ¹ / ₁₀ "D × 44"H
93"	PP93	115V	60	500	3.1	28.4	33°F to 40°F	R290	736	93"W × 33 ¹ / ₁₀ "D × 44"H
UNDERCOUNTER REFRIGERATORS										
27"	UR27	115V	60	200	2.3	7.2	33°F to 40°F	R290	184	27 ¹ / ₂ "W × 30"D × 34 ¹ / ₅ "W
48"	UR48	115V	60	290	2.3	13.4	33°F to 40°F	R290	340	48 ³ / ₁₀ "W × 30"D × 34 ¹ / ₅ "W
60"	UR60	115V	60	290	2.8	17.2	33°F to 40°F	R290	506	60 ¹ / ₅ "W × 30"D × 34 ¹ / ₅ "W
72"	UR72	115V	60	290	2.8	21.1	33°F to 40°F	R290	538	72 ⁷ / ₁₀ "W × 30"D × 34 ¹ / ₅ "W
UNDERCOUNTER FREEZERS										
27"	UF27	115V	60	260	2.3	7.2	-8°F to 0°F	R290	184	27 ¹ / ₂ "W × 30"D × 34 ¹ / ₅ "W
48"	UF48	115V	60	500	2.3	13.4	-8°F to 0°F	R290	340	48 ³ / ₁₀ "W × 30"D × 34 ¹ / ₅ "W

NOTE: Technical data subject to changes

OFFICIAL APPROVAL & RULES



W0811082.20120205

